



Encore Commercial Products, Inc.

37525 Interchange Drive, Farmington Hills, MI 48335
Toll Free 1-866-737-8900 Fax 248-354-4095
www.postguard.com

Title: Post Guard Traveler with Sign Post

Drawing Number: PGTVRSIGN

Recommended Use:

Traveling Post
Guard Cover w/ signage

Specifications: 4.5" x 52" Post
Guard Traveler with Telescoping
Sign Post

Date: 11/12/2020

Size: Various

Page: 1 of 1

Includes:

- (1) Bottom base plate with pole
- (1) Top compression rings
- (1) 4.5" x 52" Post Guard Cover
- (1) 1-1/4" x 47" Schedule 40 PVC pipe
- (1) 1" x 48" Schedule 40 PVC pipe
- (1) PVC internal domed end cap
- (4) 5/16 x 5" hex lag bolt
- (4) 3/8" flat washer
- (4) 3/8" lock washer
- (4) 3/8" wing nut
- (2) 5/16 x 2.5" hex cap
- (8) 5/16" hex nut
- (3) Wing nut
- (2) Sign bracket assemblies
- (1) 1" black pvc cap

Optional Add-Ons:

- Caster Kit
 - (2) Casters
 - (2) 5/16" x 5" long lag bolt
 - (8) #10 x 1" long pan HD machine screws
- Chain Kit
 - Yellow Plastic Chain 2" x 50'
 - Galvanized Chain 3" x 36'
- Eye Bolts
 - (2) Eye bolts

Upper Pipe:

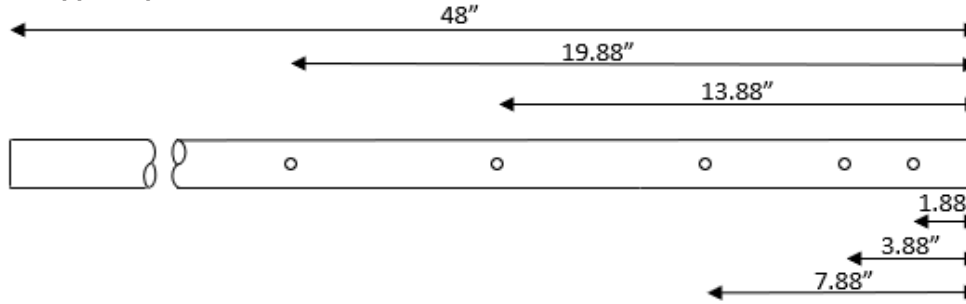

Lower Pipe:

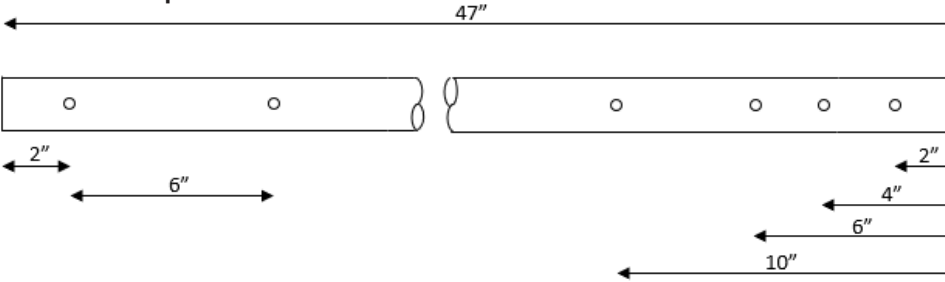

Rubber Base:

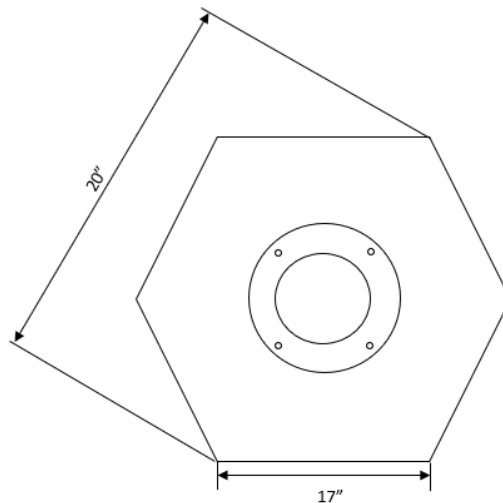

Pipe Base:

